

SWINGLOCK BIKE RACK

Dimensions and recommended clearances

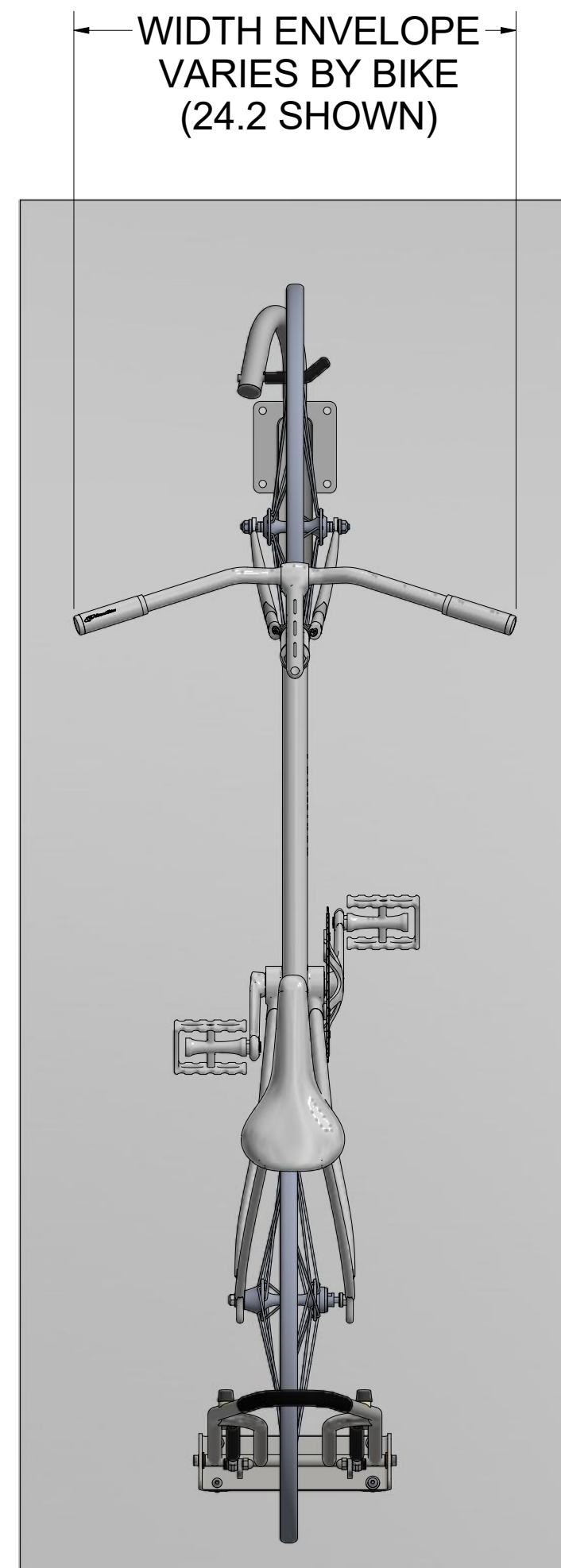
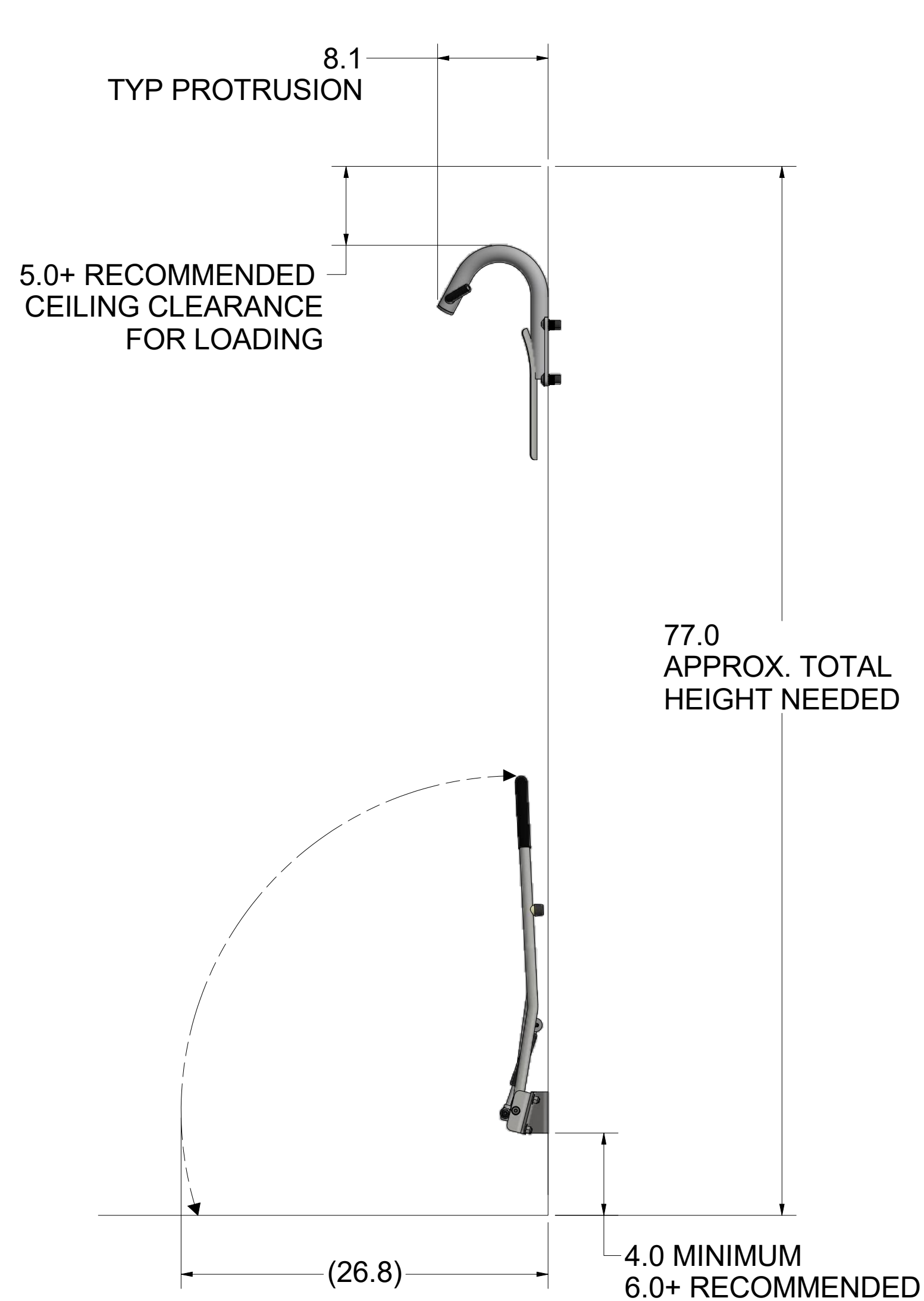
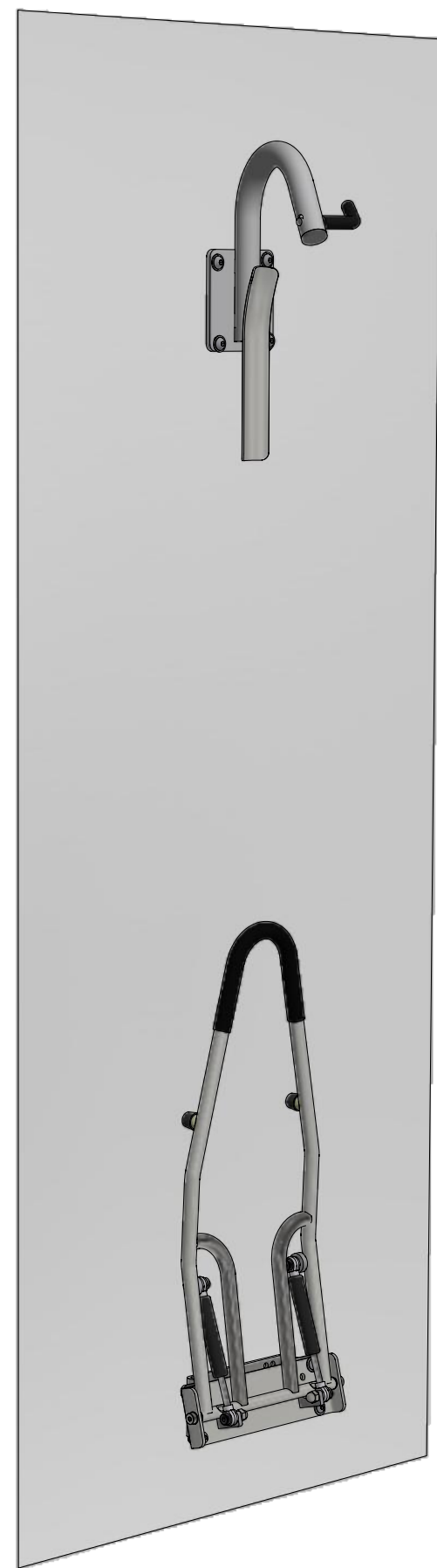

NOTES

1. SEE LAST PAGE FOR BICYCLE GEOMETRY USED IN THESE LAYOUTS

Sportworks Northwest, Inc.

15540 Woodinville-Redmond Rd. NE, Bldg A-200
Woodinville, WA 98072, PH: 425-483-7000, FX: 425-488-9001

TITLE

SwingLock Generic Layout

DWG NO.

SwingLock Generic Layout

REV

A

PROPRIETARY: THIS IS PROPRIETARY INFORMATION AND IS NOT TO BE REFERENCED OR DISTRIBUTED WITHOUT PRIOR WRITTEN AUTHORIZATION OF SPORTWORKS NORTHWEST, INC.

SIZE C2B | NO DRAWING SCALE | SHEET 1 OF 3

REV	DESCRIPTION	DATE	BY	CHK
A	INITIAL RELEASE	12/11/2018	GMC	JMS

SWINGLOCK BIKE RACK

Envelope and spacing details

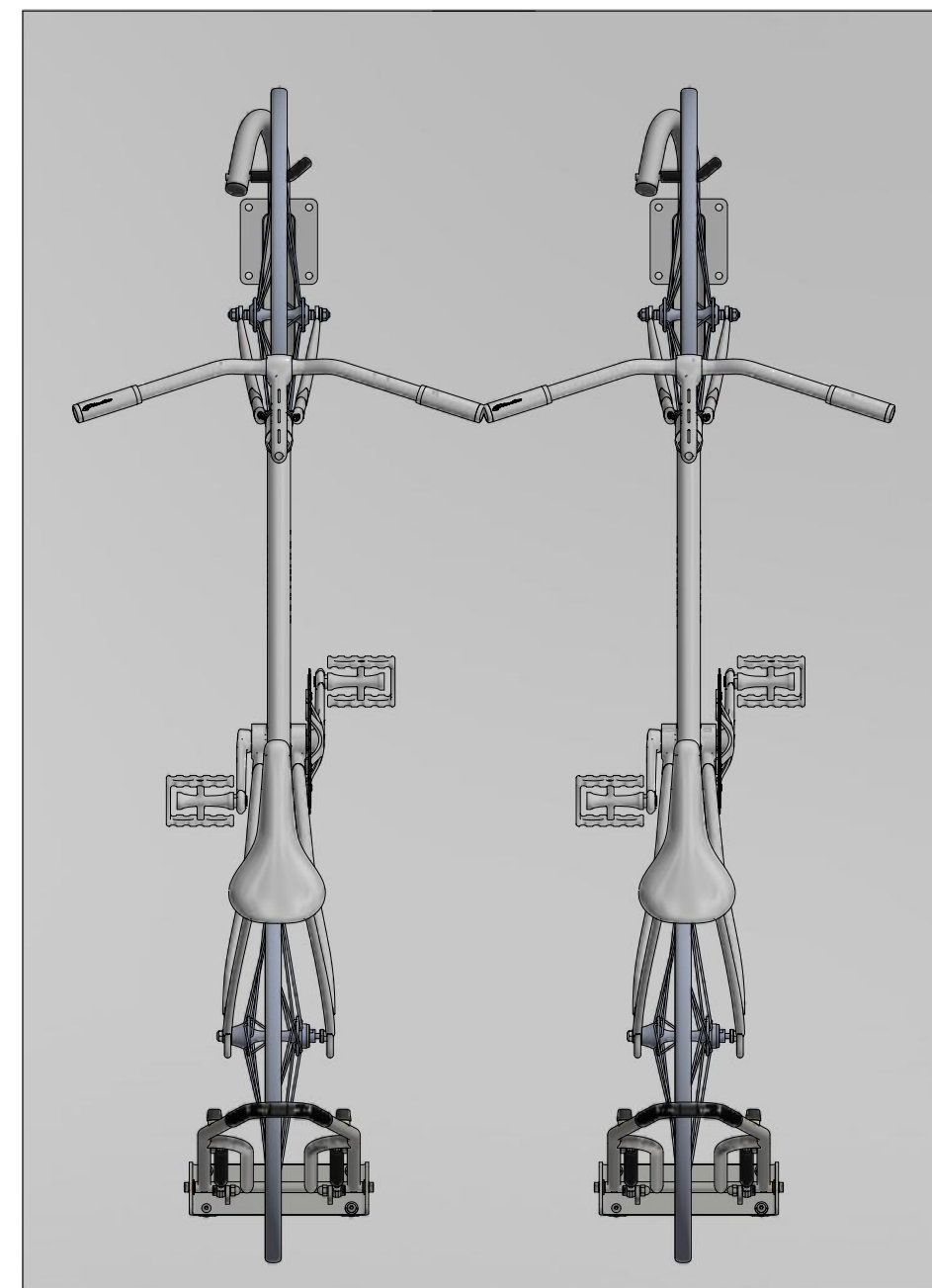
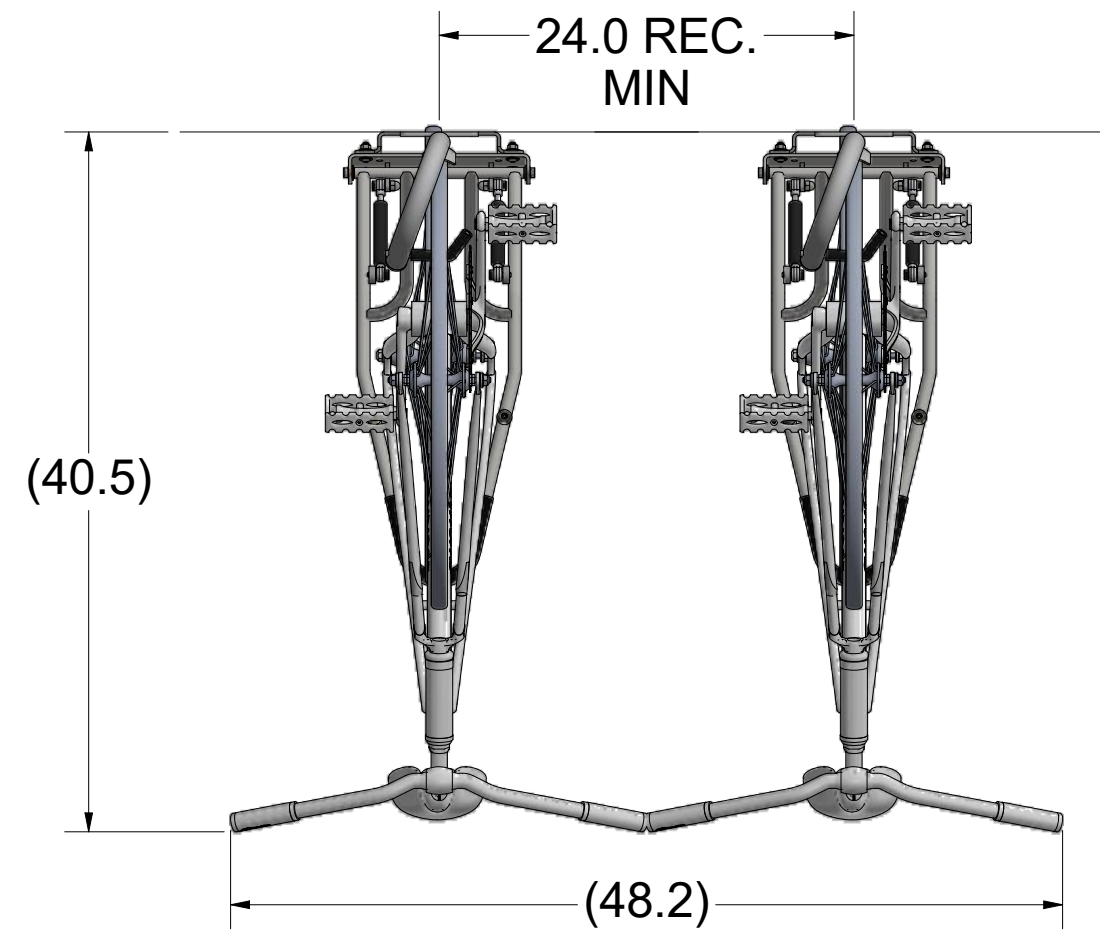

**24" SPACING
NO VERTICAL STAGGER**

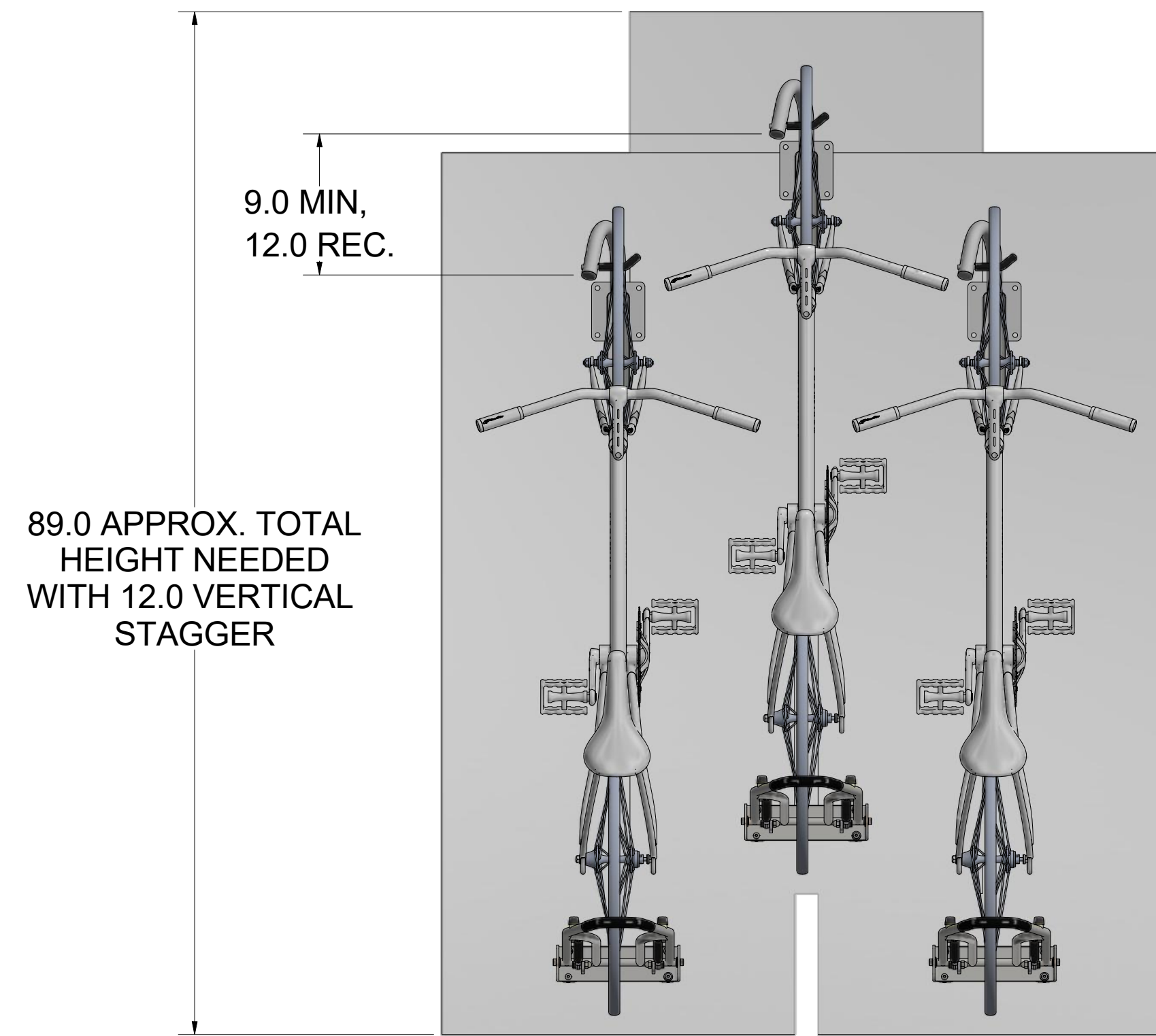
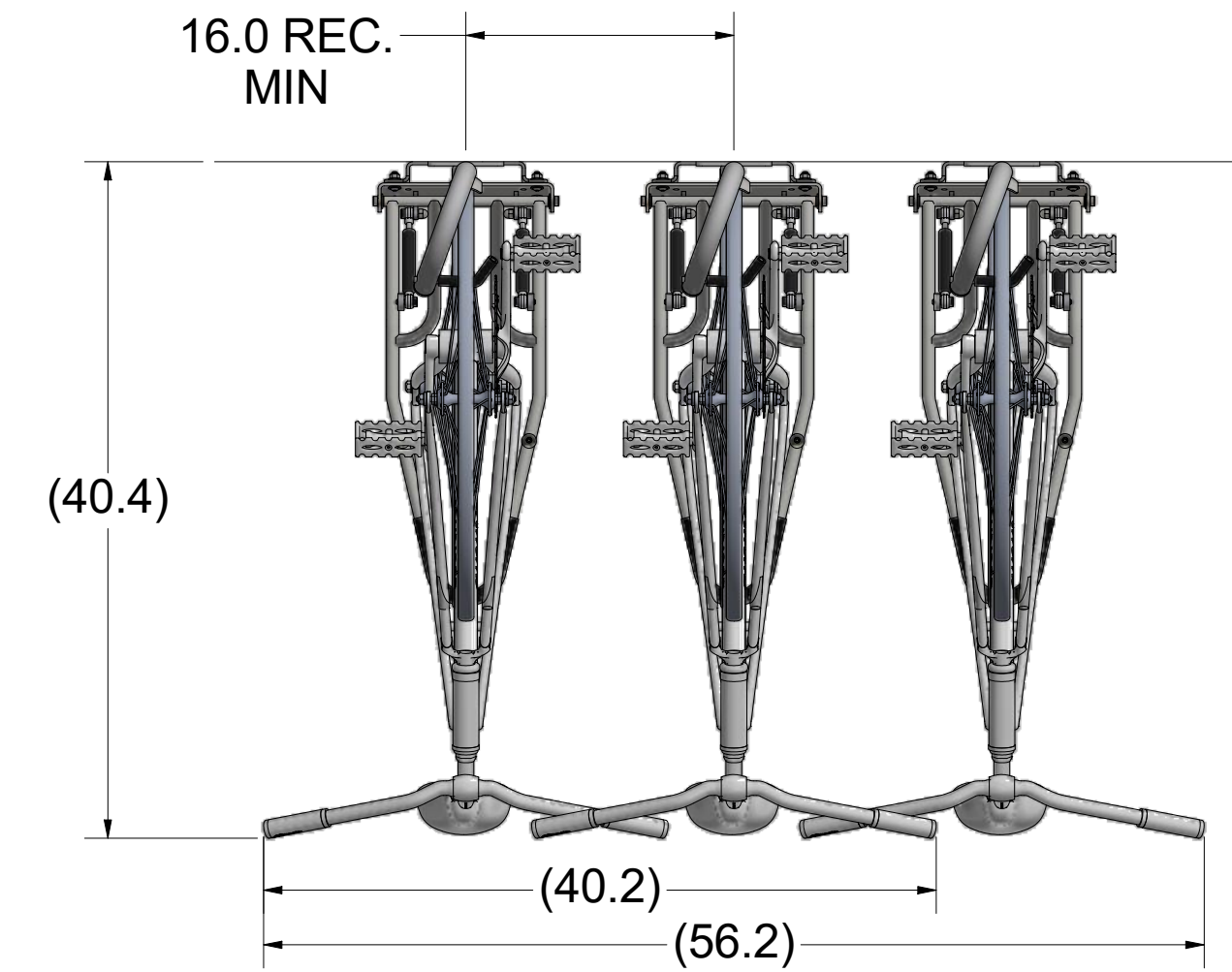

16" SPACING WITH 12" VERTICAL STAGGER

Sportworks Northwest, Inc.

15540 Woodinville-Redmond Rd. NE, Bldg A-200
Woodinville, WA 98072, PH: 425-483-7000, FX: 425-488-9001

PROPRIETARY: THIS IS PROPRIETARY INFORMATION AND IS NOT TO BE REFERENCED OR DISTRIBUTED WITHOUT PRIOR WRITTEN AUTHORIZATION OF SPORTWORKS NORTHWEST, INC.

TITLE

SwingLock Generic Layout

DWG NO.

SwingLock Generic Layout

REV

A

SIZE C2B NO DRAWING SCALE SHEET 2 OF 3

BIKE GEOMETRY USED IN THESE LAYOUTS

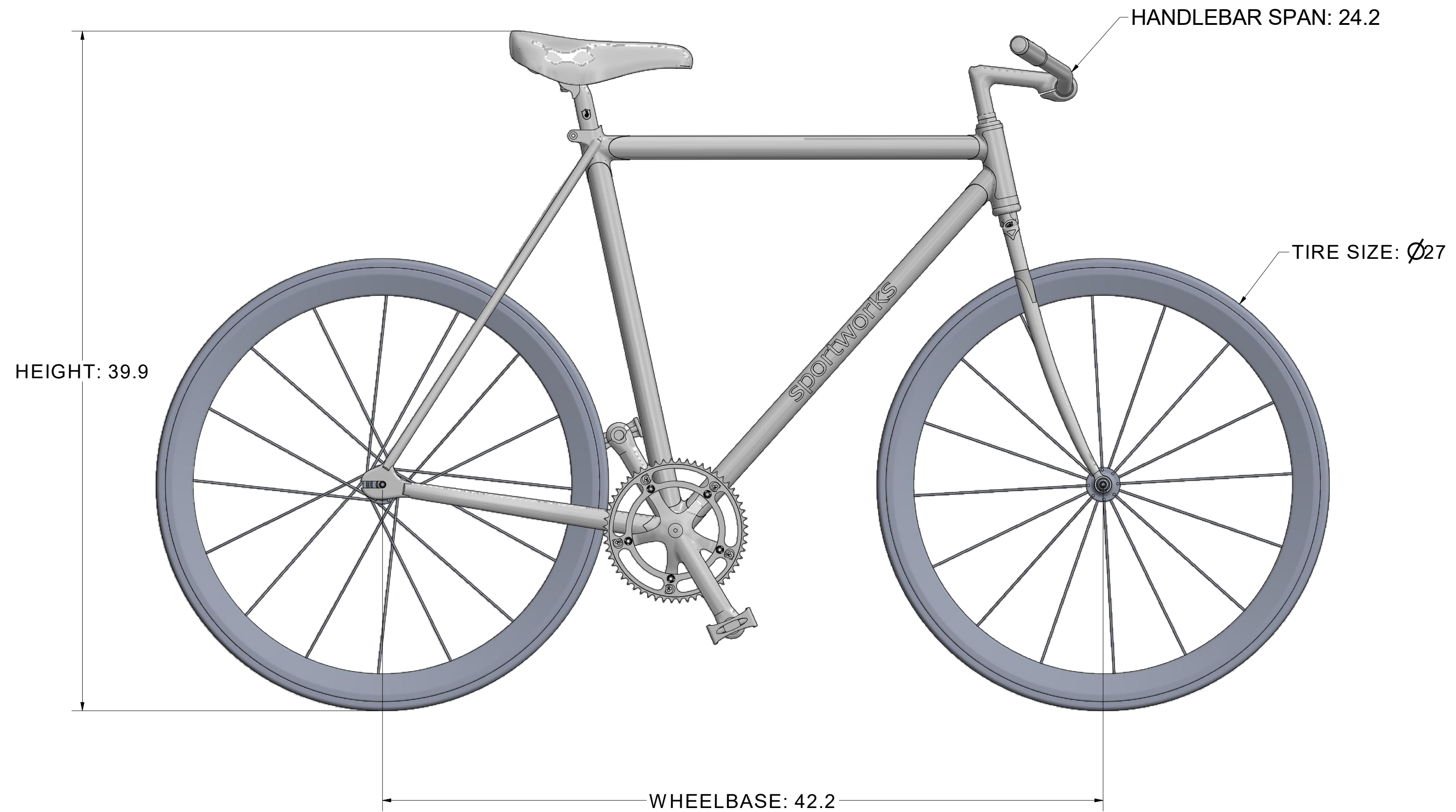

Sportworks Northwest, Inc. 15540 Woodinville-Redmond Rd. NE, Bldg A-200 Woodinville, WA 98072, PH: 425-483-7000, FX: 425-488-9001	TITLE SwingLock Generic Layout	
	DWG NO. SwingLock Generic Layout	REV A
<small>PROPRIETARY: THIS IS PROPRIETARY INFORMATION AND IS NOT TO BE REFERENCED OR DISTRIBUTED WITHOUT PRIOR WRITTEN AUTHORIZATION OF SPORTWORKS NORTHWEST, INC.</small>		
SIZE C2B	NO DRAWING SCALE	SHEET 3 OF 3